

# New Holland 200TL Series Front-End Loaders

230TL 240TL 250TL 260TL 270TL



NEW HOLLAND



# Outstanding lift capacity and visibility

200TL Series loaders match both the style and superior power of Boomer™ tractors.

The new 200TL Series loaders are the perfect fit for Boomer™ tractors, providing exceptional power, function and style.

## Curved-boom loader design

Not only does the curved design of the 200TL Series loader complement the sleek hood of your New Holland Boomer tractor, it provides better visibility and greater strength compared to the “dog-leg” loader booms you’ll

find on other tractors. The loader’s rectangular torque tube is also larger and wider for longer life and durability.

## Unmatched visibility to the bucket

Take your seat behind the wheel and you’ll find that you can easily see to the top edge of the bucket, allowing you to work confidently even when close to walls, foundations or other objects.

## Fast connection

The Quick-Mount system lets you attach the loader within minutes, take it off just as fast—without tools and does not require the customer to drive “straight only” to mount their loader. The new loader towers have ramps which allow the loader arms to slide right into place without the use of hydraulics.

## 200TL Series Front-End Loader Specifications

Loader Model	230TL	240TL	240TL	250TL
Tractor Model	TC23DA TC26DA non SuperSteer™	TC31DA TC34DA non SuperSteer™	TC31DA TC34DA w/SuperSteer™	TC35A TC35DA non SuperSteer™
Lift Capacity @ Max. Height @ 19.7 in (500mm), lbs (kg)	750 (340)	875 (397)	905 (411)	1386 (629)
Lift Capacity @ Max. Height @pins, lbs (kg)	1090 (494)	1250 (567)	1291 (586)	1800 (816)
Lift Capacity @ 39 in (991 mm) high @19.7 in (500mm)	890 (404)	1183 (537)	1226 (556)	1654 (750)
Lift Capacity @ 39 in high @pins, lbs (kg)	1188 (539)	1596 (724)	1582 (718)	2134 (968)
Breakout Force @ 19.7 in (500mm), lbs (kg)	1220 (553)	1900 (862)	1930 (875)	2376 (1078)
Breakout Force @pins, lbs (kg)	1720 (780)	2700 (1225)	2752 (1248)	3186 (1445)
Max. Lift Height, in (mm) (A)	85 (2172)	98.4 (2499)	98.7 (2507)	105 (2667)
Max. Lift Height Under Level bucket, in (mm) (B)	79 (2007)	91.8 (2332)	92.4 (2347)	97.5 (2477)
Clearance w/Bucket Dumped, in (mm) (C)	64 (1626)	75 (1913)	77 (1956)	81.5 (2070)
Reach @ Max. Lift Height, in (mm) (D)	24 (597)	31 (787)	39 (991)	32.5 (826)
Max. Dump Angle - degrees (E)	38	39	39	58
Reach @ Ground Line, in (mm) (F)	56 (1431)	70 (1778)	66 (1684)	69 (1753)
Bucket Rollback Angle - degrees (G)	28	32	32	30
Digging Depth, in (mm) (H)	2.5 (64)	8 (203)	8 (203)	6.5 (165)
Cycle Times - Seconds				
Raising Time	4.7	4.1	4.2	4.2
Lowering time	2.7	2.2	2.4	3.2
Bucket Dump Time	2.2	1.5	1.4	1.9
Bucket Rollback Time	2.8	2	1.9	2.6
Approx. Weight (Loader w/o bucket), lbs (kg)	470 (213)	560 (254)	600 (272)	730 (331)
Bucket Capacities, Struck/Heaped, cu. yd. (m³)				
48" Heavy-Duty Pin-On	.277/.336 (.212/.257)	—	—	—
54" Heavy-Duty Pin-On	.311/.380 (.238/.291)	—	—	—
60" Heavy-Duty Pin-On	—	.382/.471 (.292/.360)	.382/.471 (.292/.360)	—
60" Heavy-Duty Quick-Attach	—	.382/.471 (.292/.360)	.382/.471 (.292/.360)	—
68" Heavy-Duty Quick-Attach	—	.433/.534 (.331/.408)	.433/.534 (.331/.408)	—
72" Heavy-Duty Pin-On	—	—	—	.459/.572 (.351/.437)
72" Heavy-Duty Quick-Attach	—	—	—	.459/.572 (.351/.437)

NOTES: Specification bas



The 200TL Series loaders provide unmatched visibility to the bucket.

250TL	260TL	260TL	270TL
TC40A/TC40DA	TC35DA	TC40DA	TC48DA
TC45A/TC45DA		TC45DA	TC55DA
non SuperSteer™	w/SuperSteer™	w/SuperSteer™	non SuperSteer™
1540 (699)	1391 (631)	1545 (701)	1830 (830)
2000 (907)	1760 (798)	1955 (887)	2500 (1134)
1759 (798)	1436 (651)	1726 (783)	2213 (1003)
2317 (1051)	1939 (880)	2128 (965)	3500 (1588)
2640 (1197)	2223 (1008)	2470 (1120)	3114 (1412)
3540 (1606)	2929 (1329)	3254 (1476)	5000 (2268)
105 (2667)	106 (2692)	106 (2692)	112.3 (2852)
97.5 (2477)	99.75 (2534)	99 (2515)	104.4 (2652)
81.5 (2070)	82 (2083)	82 (2083)	85.2 (2165)
33 (838)	43.25 (1100)	43.25 (1100)	32 (813)
58	60	60	49
69 (1753)	72 (1829)	73 (1850)	79 (2007)
30	32	32	39
6.5 (165)	7.0 (178)	7.0 (178)	4.9 (124)
4.2	4.2	4.2	4.1
3.2	3.2	3.2	3.9
1.9	1.9	1.9	4.1
2.6	2.6	2.6	3.2
730 (331)	780 (354)	780 (354)	800 (363)
—	—	—	—
—	—	—	—
—	—	—	—
—	—	—	—
—	—	—	—
.459/.572 (.351/.437)	.459/.572 (.351/.437)	.459/.572 (.351/.437)	—
.459/.572 (.351/.437)	.459/.572 (.351/.437)	.459/.572 (.351/.437)	.459/.572 (.351/.437)

ASAE (S301.3) and are subject to change without notice. Dimensional and performance specifications are based on typical tractors and tire sizes.

**Added 200TL loader features that make you more productive:**

- The round smooth back of the New Holland industrial-style bucket allows for easier bucket cleaning with sticky material.
- The mid-mount loader design makes hookup easy and allows for complete turning, regardless of tire size, for easy maneuverability in confined spaces.
- New "EASY SPIN" cam pin locks the loader to the tractor mounting bracket, the new cam pin is so easy to install you can even be a quarter hole off alignment and still be able to install the pin and quickly move on to your task.



- Hydraulic lines are positioned behind the rectangular torque tube to avoid damage during heavy use, increasing durability and reliability.

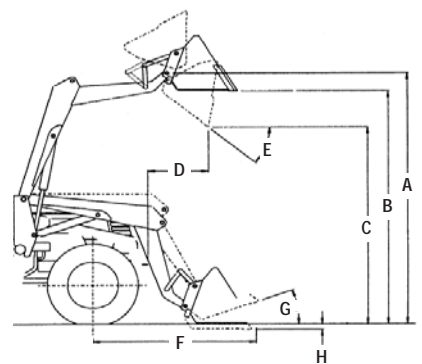

# You'll find it at the blue and white sign.



Globally, we're a valued leader in innovative agricultural and construction equipment and a wide range of financial services.

Locally, we're your trusted New Holland dealer — the specialist at the blue and white sign who's always there with the equipment, parts, service and financing you and your operation need.

Together, we're working to deliver the best value in today's dynamic world economy.

**With productive equipment.** You won't find a more complete and modern line of tractors, haytools, combines and crop production equipment — with a wider selection of models offering the latest performance, convenience and comfort features — than at your New Holland dealer.

**With quality parts and service.** Turn to your New Holland dealer after the sale for expert, factory-trained service and genuine New Holland-branded parts to keep you working productively. After all, you've placed your confidence in the best equipment, and you deserve the finest support — whether at the service counter or in the field.

**With financing solutions.** Your New Holland dealer can tell you about smart ways to maximize cash flow, preserve working capital and protect what's important.

With a portfolio of innovative financial services Financing provided by available **CNH Capital** through CNH Capital, like customized financing, leasing, insurance, and the purchasing convenience of a Commercial Revolving Account, your New Holland

dealer can turn your financial challenges into opportunities. You name it — equipment, parts and service, financing, or just trusted, honest advice on farming and finance — you'll find it all at the blue and white sign. Around the world, or right down the road, we're the company you can always turn to.



**YOUR NEW HOLLAND DEALER**



*We are proud to support the FFA.*

Visit our Web site at [www.newholland.com/na](http://www.newholland.com/na) Or, call toll-free: 1-888-290-7377

Design, materials and/or specifications are subject to change without notice and without liability therefor. Specifications are applicable to units sold in Canada, the United States, its territories and possessions, and may vary outside these areas.

© 2006 CNH America LLC. New Holland is a registered trademark of CNH America LLC. Any trademarks referred to herein, in association with goods and/or services of companies other than CNH America LLC, are the property of those respective companies.



Safety begins with a thorough understanding of the equipment. Always make sure you and your operators read the Operator's Manual before using the equipment. Pay close attention to all safety and operating decals and never operate machinery without all shields, protective devices and structures in place.

NH4270601 • 060620 • IS • PRINTED IN U.S.A.